

# DESIGN LED-LIGHTING FOR FENCES & GATES

Item No. TRICONE-



Plug & Play design led lighting for your fences & gates. Gives your gate an aesthetical look with minimal power consumption! The Quick-Fix provides a fast and strong fixing on your fencing.

- Easy mounting with Quick-Fix
- Aluminium housing with plastic (POM) cable guiding
- 3 white High-Flux led Lights
- $\pm 140^\circ$  beam angle
- Life expectancy: 50.000 hours
- 300 lux (illuminance)
- Power:  $\pm 1W$  (with 12V DC)
- 12V AC or DC (max. 18V DC or peak AC)
- Minimum power consumption and long lasting performance
- Resin encapsulated print circuit board for maximum weather resistance
- Power up to 20 Tricone with 1 Locinox AC transformer or up to 15 with the DC power
- IP54

---

## AVAILABLE IN FOLLOWING RAL-COLOURS



ZILV



RAL 9005

---

## FEATURES



---

STAY INFORMED

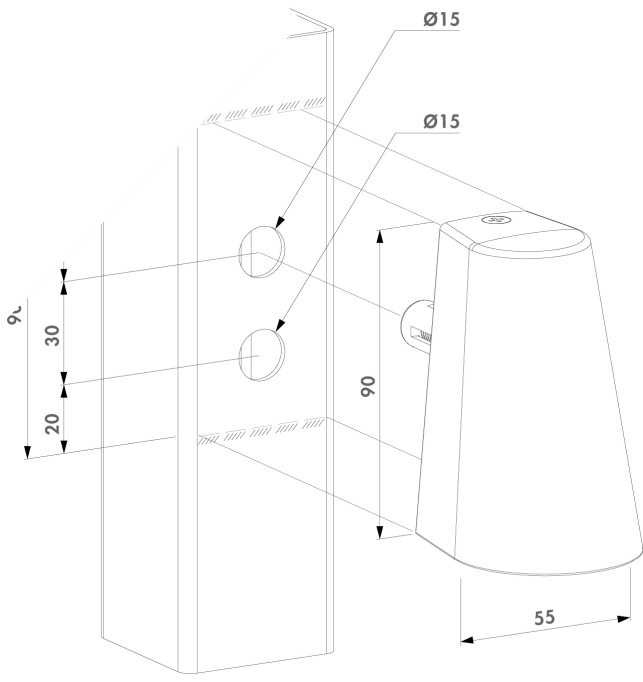

STAY INFORMED